

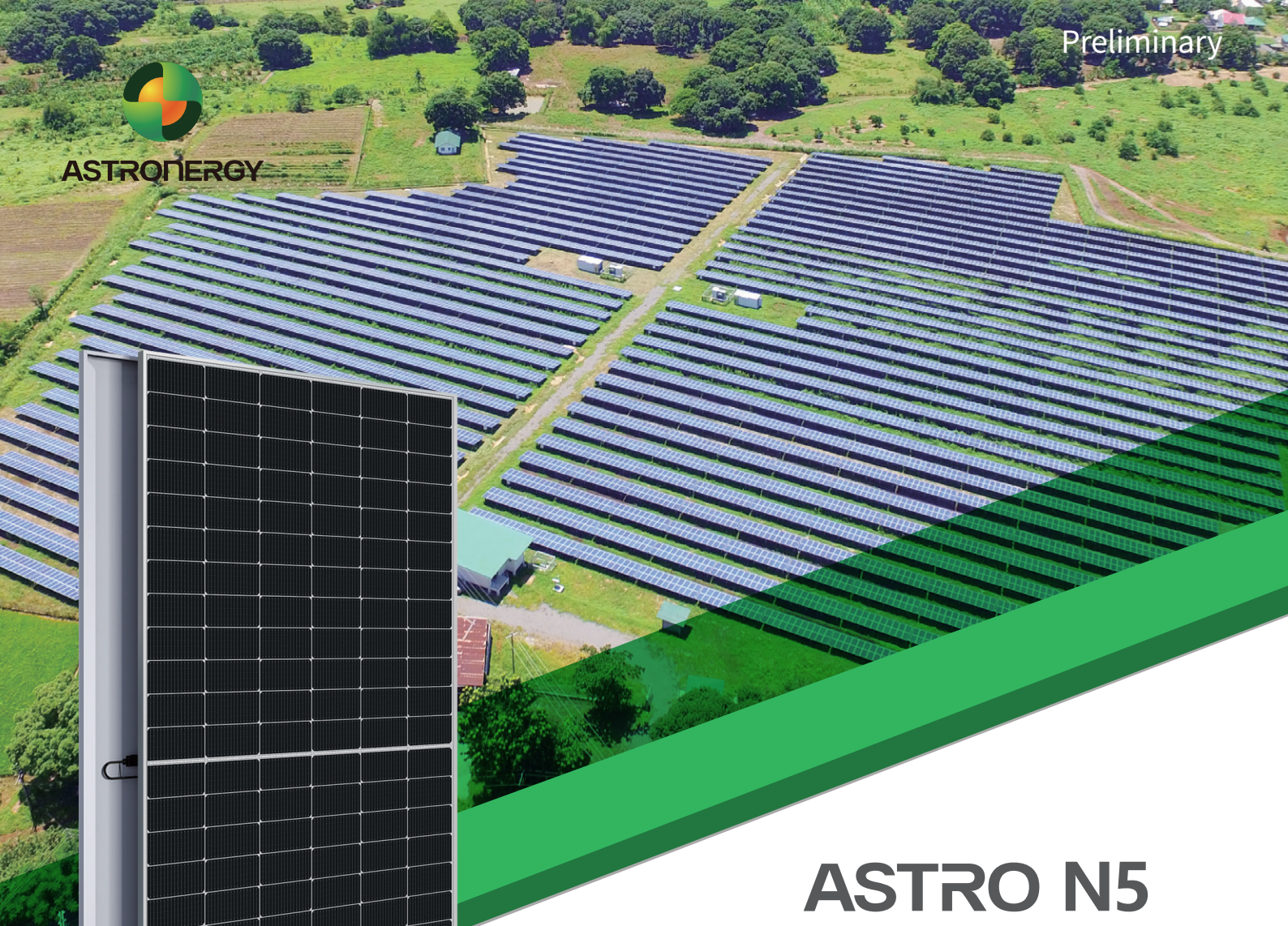

ASTRONERGY



ASTRO N5

CHSM72N(DG)/F-HC
Monofacial Series(182)

565~585W

Warranty

- 15** 15-year Product Warranty
- 30** 30-year Linear Power Warranty

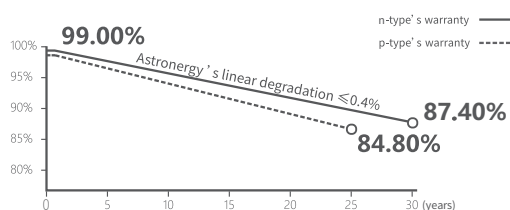

Key Features

- TOPCon / Half-cut
- Low temperature coefficient (Pmpp)
- Non-destructive cutting
- PID resistance
- Low BOS cost & LCOE



ISO 9001:2015:ISO Quality Management System
ISO 14001:2015:ISO Environment Management System
ISO 45001:Occupational Health and Safety
The first solar company which passed the Nord IEC/TS 62941 certification audit



Tier 1
BloombergNEF



565~585W

POWER RANGE

0~+5W

POWER SORTING

22.6%MAX MODULE
EFFICIENCY**≤ 1.0%**FIRST YEAR
POWER DEGRADATION**≤ 0.4%**YEAR 2-30
POWER DEGRADATION

Mechanical Specifications

Outer dimensions (L x W x H)	2278 x 1134 x 30 mm
Cell type	n-type mono-crystalline
No. of cells	144 (6*24)
Frame technology	Aluminum, silver anodized
Front / Back glass	2.0+2.0 mm
Cable length (Including connector)	Portrait: (+)350 mm, (-)250 mm; Customized length
Cable diameter (IEC/UL)	4 mm ² / 12 AWG
① Maximum mechanical test load	5400 Pa (front) / 2400 Pa (back)
Connector type (IEC/UL)	HCB40 (Standard) / MC4-EVO2A (Optional)
Module weight	32.1 kg
Packing unit	36 pcs / box
Weight of packing unit (for 40'HQ container)	1207 kg
Modules per 40' HQ container	720 pcs (Subject to sales contract)

① Refer to Astronergy crystalline installation manual or contact technical department.
Maximum Mechanical Test Load=1.5×Maximum Mechanical Design Load.

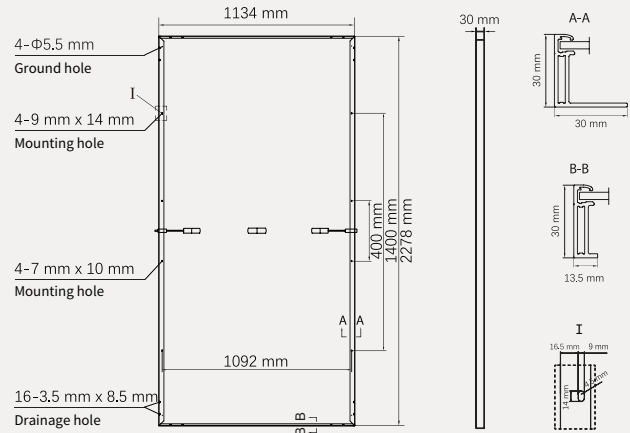

Electrical Specifications

STC: Irradiance 1000W/m², Cell Temperature 25° C, AM=1.5

	565	570	575	580	585
Rated output (Pmpp / Wp)	565	570	575	580	585
Rated voltage (Vmpp / V)	43.57	43.70	43.82	43.95	44.08
Rated current (Impp / A)	12.97	13.04	13.12	13.20	13.27
Open circuit voltage (Voc / V)	51.85	52.00	52.15	52.30	52.45
Short circuit current (Isc / A)	13.69	13.79	13.89	13.98	14.08
Module efficiency	21.9%	22.1%	22.3%	22.5%	22.6%

NMOT: Irradiance 800W/m², Ambient Temperature 20° C, AM=1.5, Wind Speed 1m/s

	424.9	428.6	432.4	436.2	439.9
Rated output (Pmpp / Wp)	424.9	428.6	432.4	436.2	439.9
Rated voltage (Vmpp / V)	41.01	41.13	41.25	41.37	41.49
Rated current (Impp / A)	10.36	10.42	10.48	10.54	10.60
Open circuit voltage (Voc / V)	49.25	49.39	49.54	49.68	49.82
Short circuit current (Isc / A)	11.05	11.13	11.21	11.29	11.37

Temperature Ratings (STC)

Temperature coefficient (Pmpp)	-0.29%/°C	No. of diodes	3
Temperature coefficient (Isc)	+0.043%/°C	Junction box IP rating	IP 68
Temperature coefficient (Voc)	-0.25%/°C	Max. series fuse rating	25 A
Nominal module operating temperature (NMOT)	41±2°C	Max. system voltage (IEC/UL)	1500V _{DC}

Operating Parameters

Curve

